



26-05-2008

**OXIMO 50 S AUTO RTS TH TECHNICAL DATA**

SDEV-CLU-IMPS 61R1  
SDEV- FICA 09 R0  
ILMO 50 S AUTO RTS TH R0

Type of head	Thin head
Nominal voltage	230 V - 50Hz
Power supply tolerances	207 - 253 V
Thermal time	4 minutes
Number of wires of the cable	3
Wire section	0,75 mm <sup>2</sup>
Type of limit switch unit	Electronic
Repeatability	Stop always at the torque detection limit for nominal torque
System of protection	IP 44
Interface drawings	Screw implantation for LT50 mounting 206810-Wheel interface LT50 206821-Crown interface LT50 206822-LT50 and LT50PA/PS star head interface drawing: 206823-
Insulation class	Class 2
Type of adjusting of the end limits	Self detection of rotation and Automatic ajustement dedicated to Roller shutter with rigid fasteners and stoppers
End product protection	In the up and down direction
Accessories compatibility	ABS wheel: Not Compatible - Differential: Not compatible - Double insulation accesories : Compatible
Electrical safety	EN60335-1: 2002 + A11:2004 + A1:2004 + A12:2006 + A2:2006 / EN60335-2-97: 2006 / EN60950-1:2006
Health test	EN50371 : 2002 / EN50366 : 2003 + A1:2006
Electromagnetic compatibility	EN55014-1:2006 / EN55014-2:1997 + A1:2001 / EN301 489-1 V1.8.1 : 2008 / EN301 489-3 V1.4.1 : 2002 / EN61000-3-2 : 2006 / EN61000-3-3 : 1995 + A1:2001 + A2:2005
Radio	EN300220-1 V2.1.1 : 2006 / EN300220-2 V2.1.2 : 2007
Frequency	433,42 MHz
Antenna	length: 170 mm
Maximun time of fonctionning without stop	2 minutes
Basic crown for tube Ø	50 x 1,5 mm
Temperature working range	Normal use : -10°C to +40°C Exceptionnal use (20% of the life time not simultaneous) : -20°C to + 70°C
Noise level	According to SOMFY mesures (for information only).Worse value : with load in up direction during 10 seconds.

Designation	Nm	rpm	Reference	mm	mm	mm	mm	W	A	°C	kg	dBA	mm	µF
	Nominal torque	Nominal speed		L1 max.	L2 (±3 mm)	L3 max.	tube	Rated power	Rated current	Thermal	Brake type	Noise	Stator	Capacitor
<b>Tubular S Module 6/17 TH</b>	<b>6</b>	<b>17</b>	5052791A	367		375	302	90	0.4	140	sliding	46	35	2.5
<b>OXIMO RTS Module</b>			5053639A											

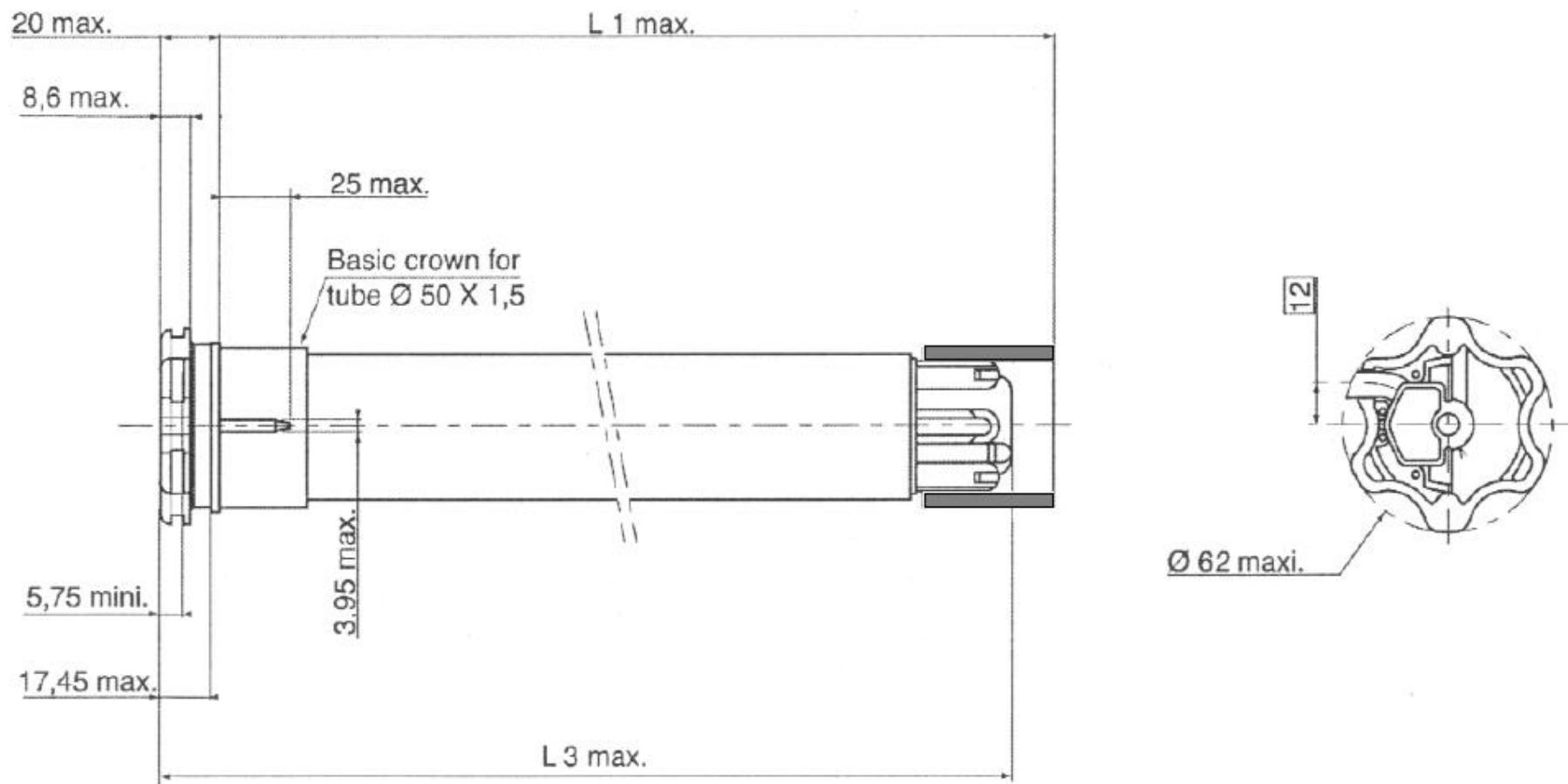

Name Date	R&D	QUALITY	EDITOR

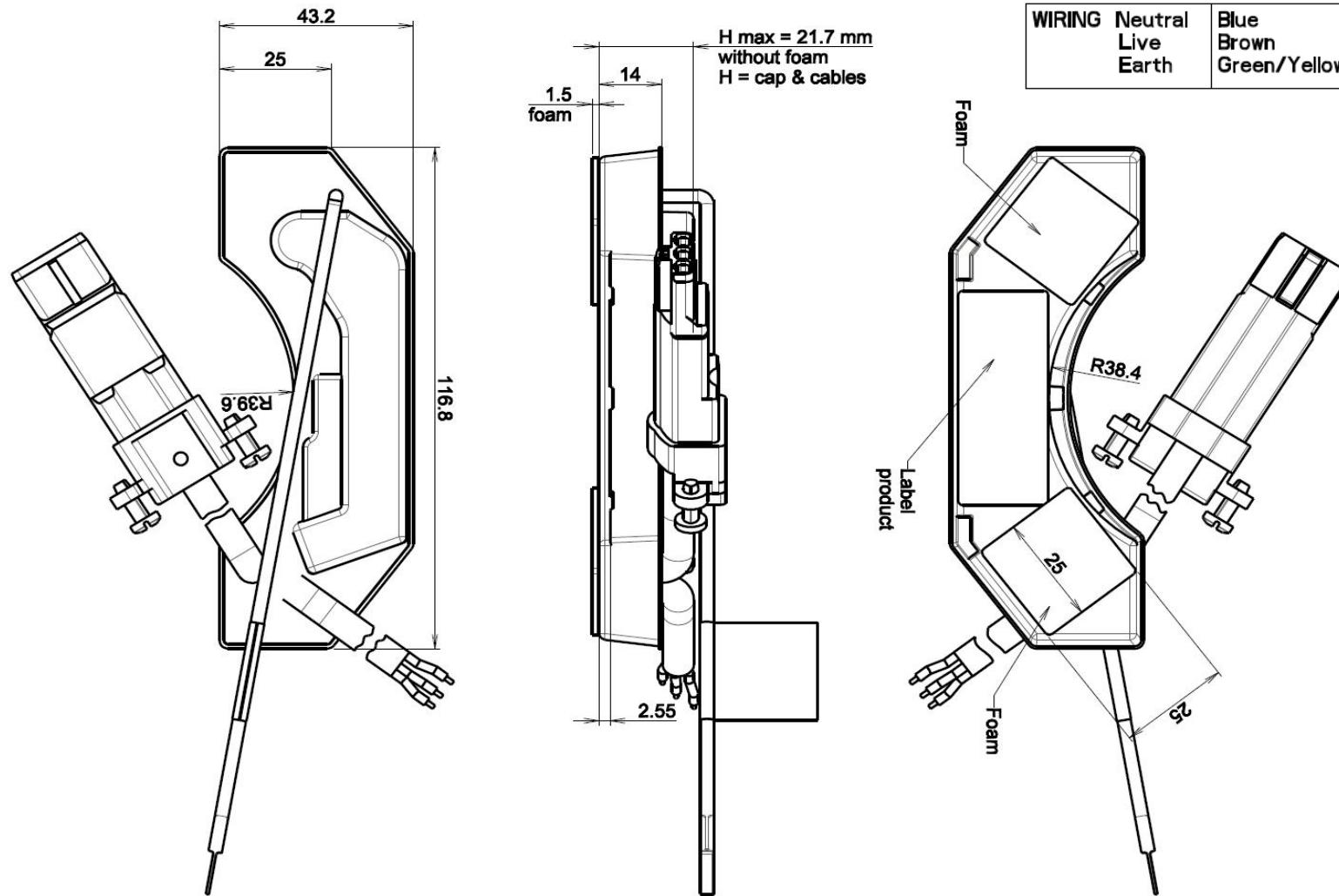

Name Date	R&D	QUALITY	EDITOR