



12/02/98

**FTS 60 TECHNICAL DATA**

DMKI - FPTE  
RANGE 3  
FTS60Range3R0

Nominal voltage	100 V - 50/60 Hz
Power supply tolerances	95 - 107V
Thermal time	7 minutes
System thermal time (50 Hz)	dynamic brake and final tension mini : 17 minutes dynamic brake and final tension max : 13 minutes
Number of wires of the cable	5 <b>Non removable 1 m VV-F grey cable</b>
Wire section	0,75 mm <sup>2</sup>
Type of limit switch unit	Quick limit switch
Capacity of the LSU	35 turns
Repeatability	± 5°
System of protection	IP 44
Interface drawings	Wheel interface LT60 206801-Crown interface LT60, LT60ADF, FTS60 & LT60CSI 206802-Interface drawing star head LT60 206803-Interface drawing LT50&60 buttons 206817.
Basic crown for tube Ø	63 x 1,5 mm
Electronic control box	Ref. ESFT826140 (110V/50-60Hz)
Temperature working range	Normal use : -10°C to +40°C Exceptionnal use (20% of the life time not continuous) : -25°C to + 70°C
Noise level	According to SOMFY measures (for information only).Worse value : in load up direction during 10 seconds.

Designation	Nm	rpm	reference	mm			tube	W	A	°C	Brake type	kg	dBA
	Nominal torque	Nominal speed		L1 max.	L2 (±3 mm)	L3 max.		Rated power	Rated current	Thermal tripping		Weight	Noise
FTS 655A3	5 5	17/20	200515	964	677	700	630	440	4,3	140	coil brake	5	-

WIRING	Neutral	White
	White button	Black
	Yellow button	Red
	Brake	Grey
	Earth	Green

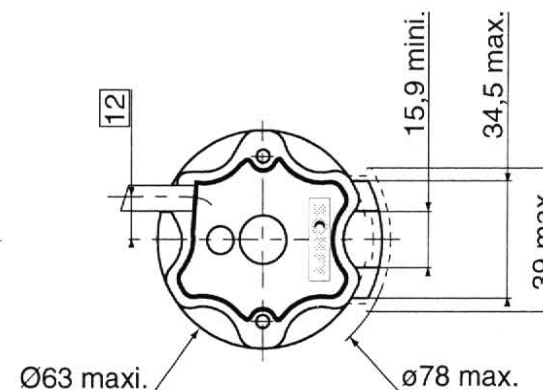
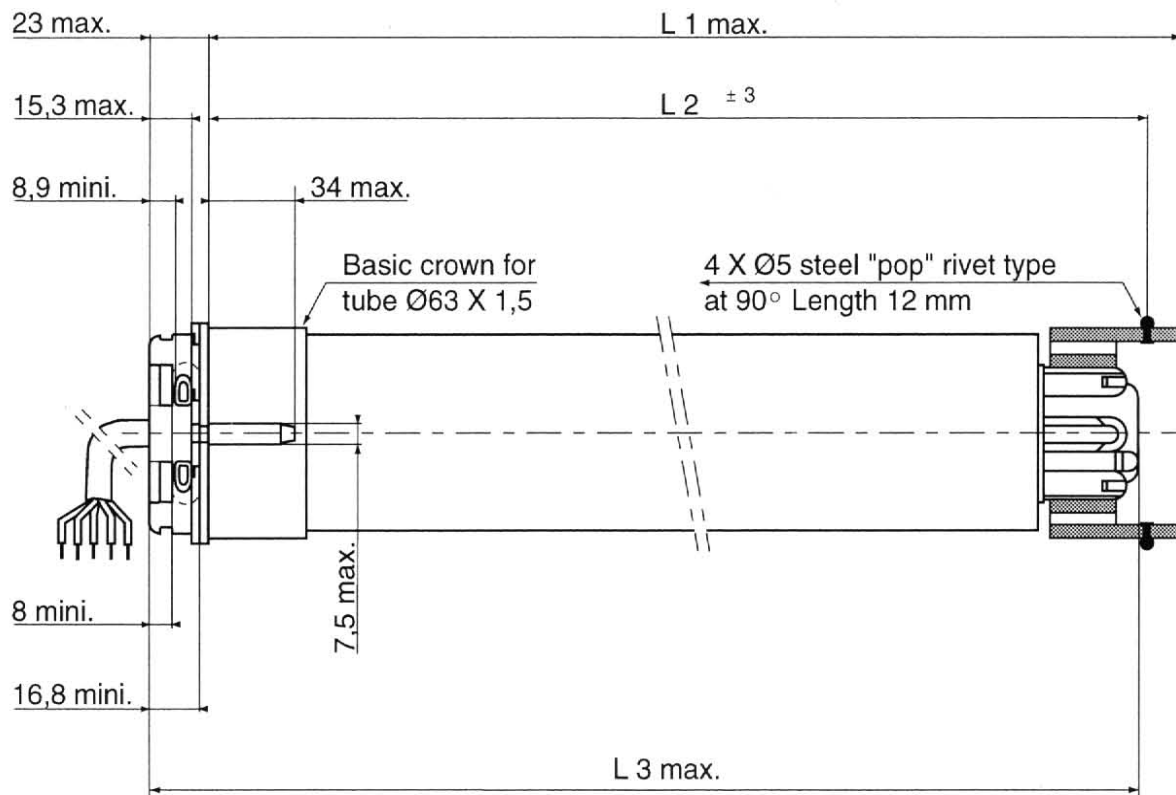

Visa : BEM *[Signature]*
Quality *[Signature]*
MKI *[Signature]*